

# CE0-SAL5-E01 USER MANUAL

## Double system for large cockpit vehicle



### Table of Contents

1. COMPONENTS AND CONNECTION OF THE ELECTRICAL CONTROL.....	2
2. INSTALLING THE ELECTRICAL CONTROL BOX .....	7

# 1. COMPONENTS AND CONNECTION OF THE ELECTRICAL CONTROL

## Electrical control components

	Q.ty	Use	
		Cockpit	Vehicle exterior
Electrical box	2	2	
Cable	8	4	4
Internal activation button	1	1	
External activation button	2		2
Stickers	3	1	2
Fireproof sleeves		As needed	As needed



**WARNING**

The Electrical Control Unit is IP 55 certified. However, if the Control Unit circuit gets wet, unwanted activation of the extinguishing system might occur.

See paragraph 2 about the control unit installation aimed to minimize the risk of water penetrating the unit.

### Electrical connections diagram

Your system can be activated in two ways: by the internal activation button, or by the external activation buttons.

The general wiring diagram is shown in Figure 16.

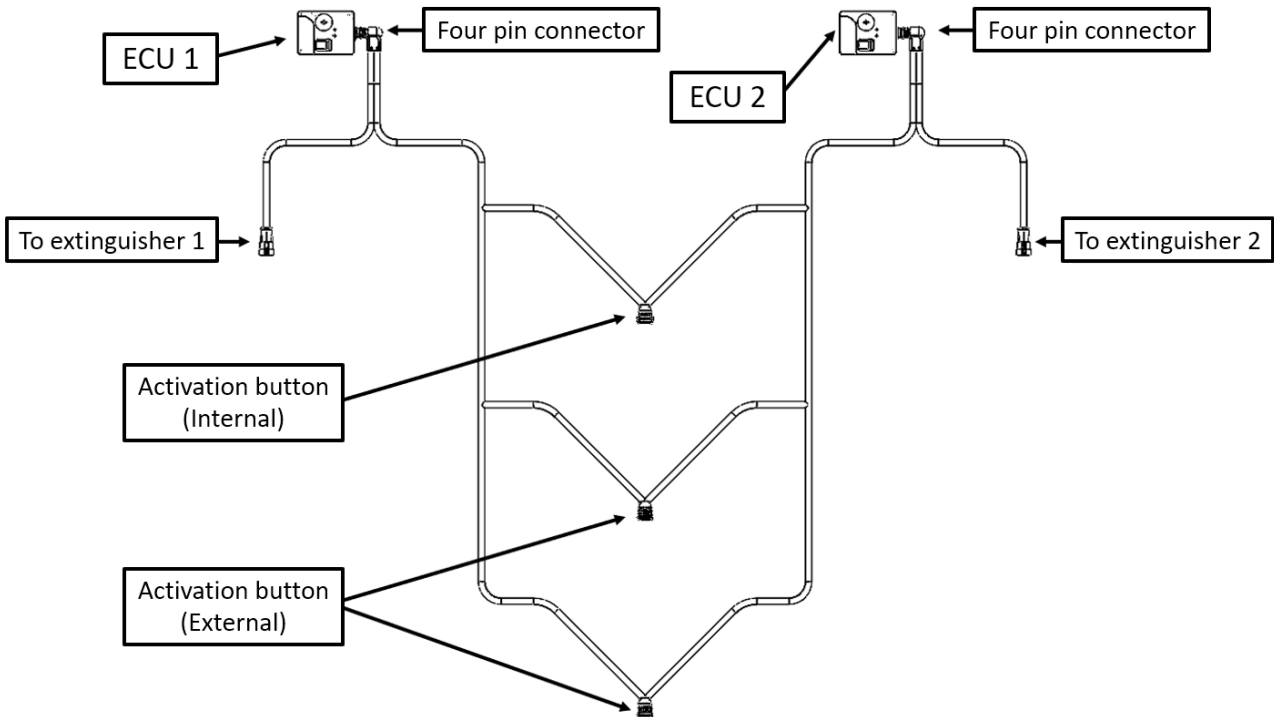

Fig. 1 Electrical connection layout



## **WARNING**

**Each ECU has an independent circuit and MUST NOT be connected to each other.**

**Each DPDT activation button triggers the two ECUs separately at the same time.**

**The two cables of a single activation button MUST be connected to a different ECU, to avoid the connection of the two circuits.**



## **WARNING**

**DO NOT use any different activation button, only the DPDT button of this kit.**

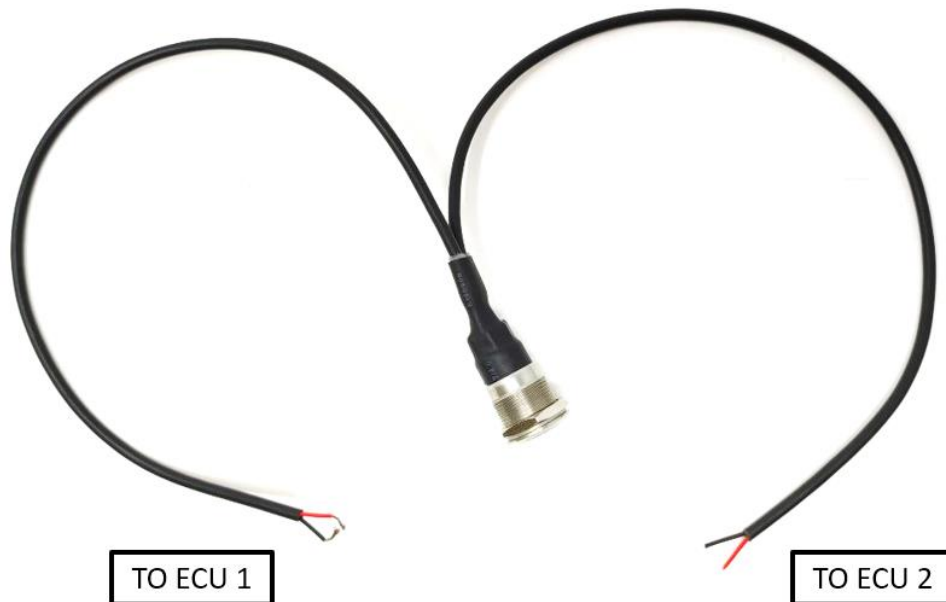

Each control unit includes:

- A switch for the TEST and the ARMED mode
- 2 LEDs (orange and red) for the output
- A 4 pins connector to connect the bottle and the external push button.

### **Switch in TEST position:**

Before every race is mandatory to test the fire extinguisher system to check the integrity of wiring, battery level etc.

Set the switch in TEST position. In TEST mode the fire extinguisher system cannot be activated.

To run the TEST, push one activation push button. It is recommended to perform 3 different tests, one for each activation button.



### WARNING

Each ECU works independently. To run the test, the switches on both the ECUs must be set in TEST position.

If one of the 2 ECU is in armed position and you push one of the buttons, the ECU in armed mode will activate the extinguisher system.

The TEST can give two different results: test OK and test FAILED.

Test OK:

1. After releasing the activation button, the orange LED starting to be constantly on for at least 5 seconds. After this time the LED goes out. The fire extinguisher system works properly.

Test Failed:

If the TEST is failed there can be 2 different outputs.

1. The orange LED start to flash for at least 10 seconds after which it turns off. This output means there is a technical problem (electrical discontinuity, bottle issue etc.)
2. Red LED and orange LED start to flash together. In this case the battery is low and must be replaced.



### WARNING

Before replacing the battery, set the control unit in TEST mode.

If after a new installation or replacing the battery the orange LED during the TEST mode stays on, means that one of the activation buttons is closed (pressed or in short circuit) or a part of the wiring connected to the external button have a short circuit.

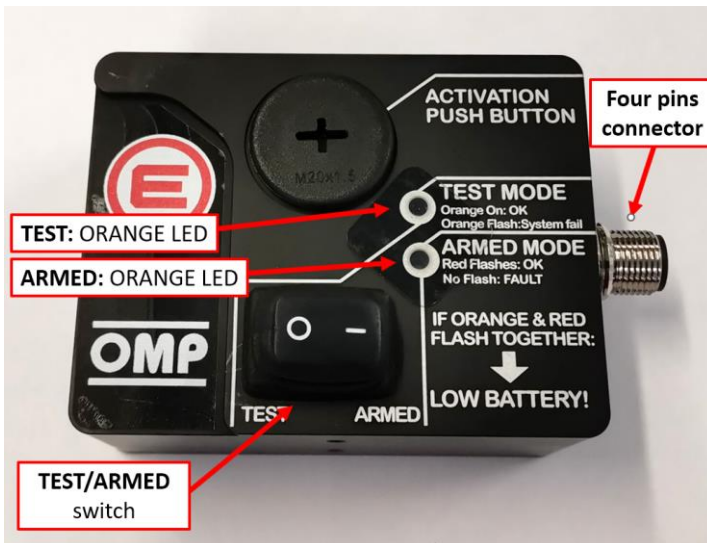

Fig. 2 Control unit

#### Switch in “ARMED” position:

When the switch is moved from TEST to ARMED position the control unit run an automatic check to find anomalies.

Output of the TEST in ARMED mode:

TEST OK

- If the TEST is OK, the orange LED is on for at list 5 second after that the red LED start to flash. When the RED led is flashing, the system is ready to fire. Pushing one of the activations buttons the extinguisher system can be activated.

## TEST FAILED

- If the orange LED start to flash at least 10 seconds, the TEST is failed, and the RED LED doesn't start to flash (the control unit is not armed). There is therefore a technical problem (wiring problem, bottle disconnected etc.)
- If the red and the orange LEDs starting to flash at the same time, the battery is low ant it must be replaced with a new one.

During the use of the armed control unit:

- If red LED and orange LED flashing together, the battery is low, and it shall be replaced. There is little autonomy time before the total discharge.
- If the red LED is on continuously, the bottle is disconnected.
- The control unit is armed and ready to fire till the switch is setted in armed position. After every race and when the fire extinguisher system is not needed, is recommended to set the switch in TEST mode to avoid unwanted activation (pushing a button accidentally etc.) and battery drain.

## Control box pin-out:

The output of the control box passes through an IP67 certified 4 pin connector.

The connector pin-out is shown in Figure 18:

- Pins 1 and 2: connection to the external button (not polarized)
- Pins 3 and 4: connection to the bottle (not polarized)

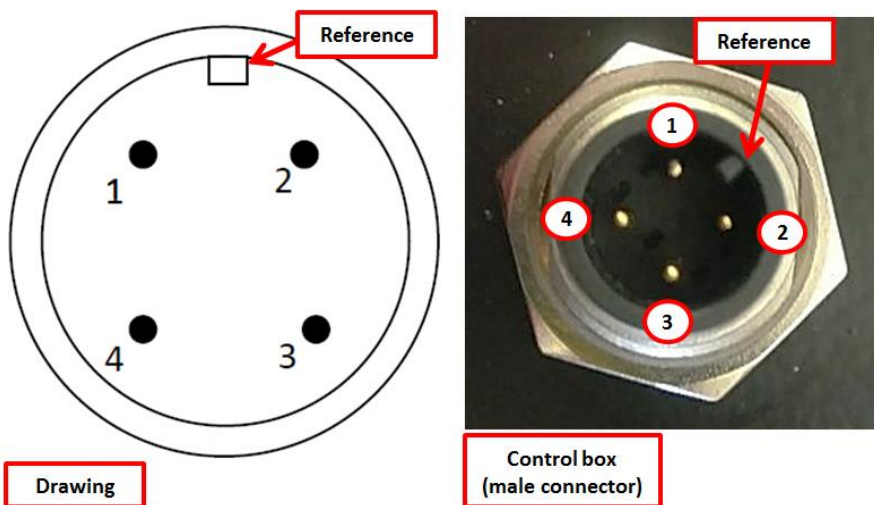

Fig. 3 Control unit pin-out

Obviously, in cable female connector, pins are mirrored, as shown in Figure 19.

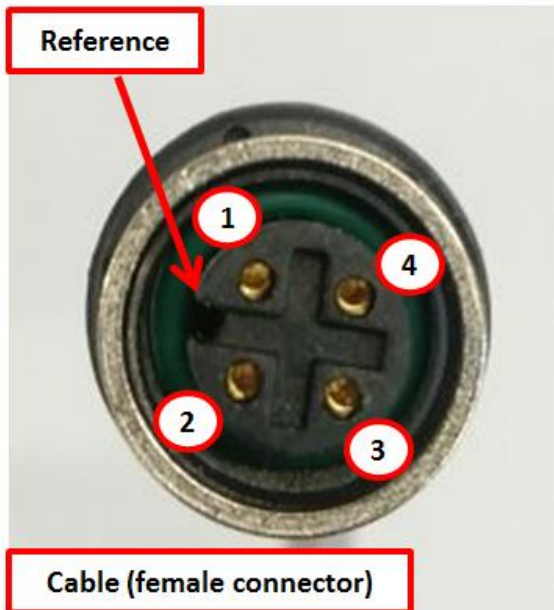

Fig. 4 Female connector (wiring side)

#### Extinguisher system wiring

the system includes:

- **Two Control units**
- **Two Control unit wirings**, each one with two raw ends and the other end with a 4-pin connector to connect to the control unit. The black wire is used to connect the bottle, the yellow wire is used to connect the internal button and the two external buttons.
- **Two electrical wirings** (one per each bottle) with one raw end and one end with a plug for the connection of the extinguisher bottle.
- **One internal activation push button**
- **Two external activation push buttons**
- **Fireproof sleeves** to protect the wiring in case of fire.



#### **WARNING**

**All the electrical cables shall be covered with the fireproof sleeves provided with the system. Remember to cover the cable with the fireproof sleeve before weld or fix the different parts of it.**

The cable shall be covered with fireproof sleeves to protect it in case of fire, as shown in Figure 21.

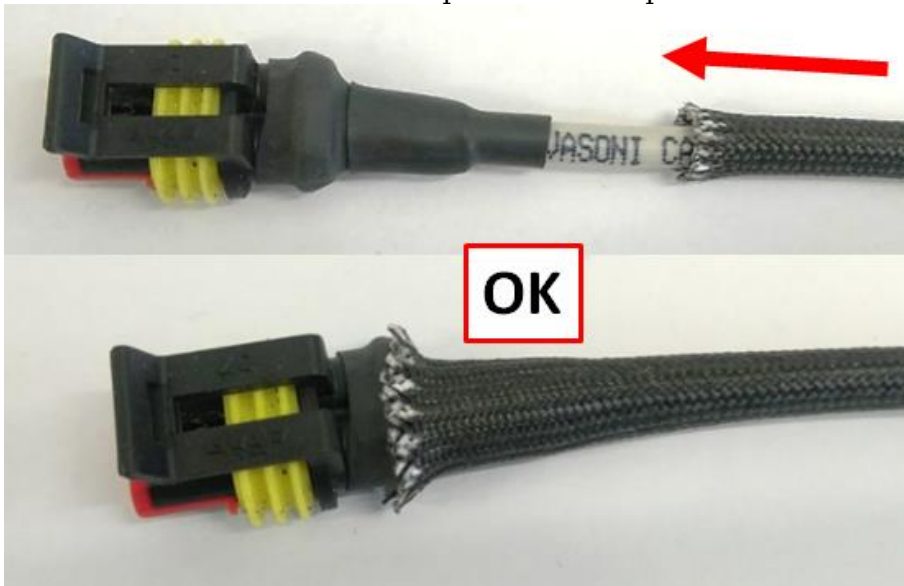

Fig. 5 Fire proof sleeve installation



### **WARNING**

**Before connecting the electrical cables to the bottle and control units, check the proper matching of the pin out connection with a multimeter, or similar device.**

An error in the electrical connection can cause a failure of the extinguisher system. Follow the pin-out drawing shown in Figures 18 and 19.

**DO NOT RELY ON THE CABLE COLOR**, which may vary from system to system. Instead, **RELY ON THE POSITION** of plugs.



### **WARNING**

**Joint the 2 wires by welding or using connector (i.e., Faston). All joints between the cables must be properly insulated, to avoid malfunctions.**

The four-pin control unit connector is equipped with a locking mechanism, so that it will not come loose by accident.

The position of the control unit shall comply with the following requirements:

- Control units and internal activation button shall be reached by the drivers (and co-drivers, if any) seated in driving position with the seat belt tight.
- It shall always be possible to see the unit LED in all conditions.
- The control unit shall be protected from direct exposure to water.

The external buttons shall be mounted outside the vehicle.

Three adhesive marks, provided with the system, shall be located near both activation buttons.

When the black switch on both the ECUs is in ARMED position, whenever either of the buttons is pushed, the extinguishing medium will be immediately expelled from the nozzles and the spray cannot be stopped.

Therefore, it is advisable to set both switches to TEST position when the vehicle is not used, and to switch them to ON when the vehicle is started.

If the car is not used for a long period, remove the battery from the control box.



### **WARNING**

**When the control box switches are set to TEST position, the extinguishing system is disabled. Make sure that the switch is in ARMED position before using the vehicle.**

## **2. INSTALLING THE ELECTRICAL CONTROL BOX**

The position of the control unit shall comply with the following requirements:

- Control units and internal activation button shall be reached by the drivers (and co-drivers, if any) seated in driving position with the seat belt tight.
- It shall always be possible to see the unit LED in all conditions.
- The control unit shall be protected from direct exposure to water.



### **WARNING**

**The Electrical Control Units are IP 55 certified but if their internal circuit gets wet, unwanted activation of the extinguishing system might occur. Tighten the screws properly.**

Care shall be taken to install the Control Units in an area where it is protected from direct splash of water. If it is not possible to place the Control Units in an area where it is protected from water: it shall be protected with a waterproof nylon or similar material cover.

It is suggested never to install the control boxes directly on the floor without using a raising spacer. If the control unit is installed on the floor, it shall be at least 15 mm raised by a spacer.

Open the rear compartment of the control unit (fastened with 4 screws) and install a fully charged 9V battery into the control unit, then reclose the compartment with the provided screws; (See Figure 22)



**Only use alkaline battery. Don't use rechargeable battery, zinc-carbon battery and battery specified for low energy absorption device. Recommended 9V battery are 6LR22/6LR61.**

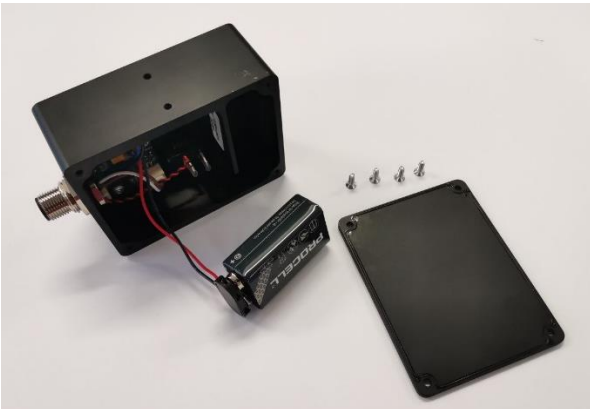

Fig. 6 Battery connection

Secure the control units in the vehicle with at least two M3 screws.

Position the two external buttons outside the vehicle near the windshield bottom on the driver's side, then connect and secure them in place with the ring nut.



**To avoid unwanted activations and malfunctions of the system, DO NOT connect the electrical circuit to a common ground or power source.**



**Any short circuit between the connecting elements on the rear of the button is read by the system as an activation signal. When installing all components make sure that they are protected from the short circuit risk (for example due to a contact with external parts or a splash of water).**

**To avoid unwanted activations, DO NOT connect the control units.**

If possible, protect each connection with silicon caulk, heat shrink tube or similar items.

To complete the connection from the control unit to the system bottle, insert the plug until the locking lever reaches its reference, as shown into Figure 23.

It is strongly recommended to set both the switches to TEST mode before connecting the control unit to the bottles.



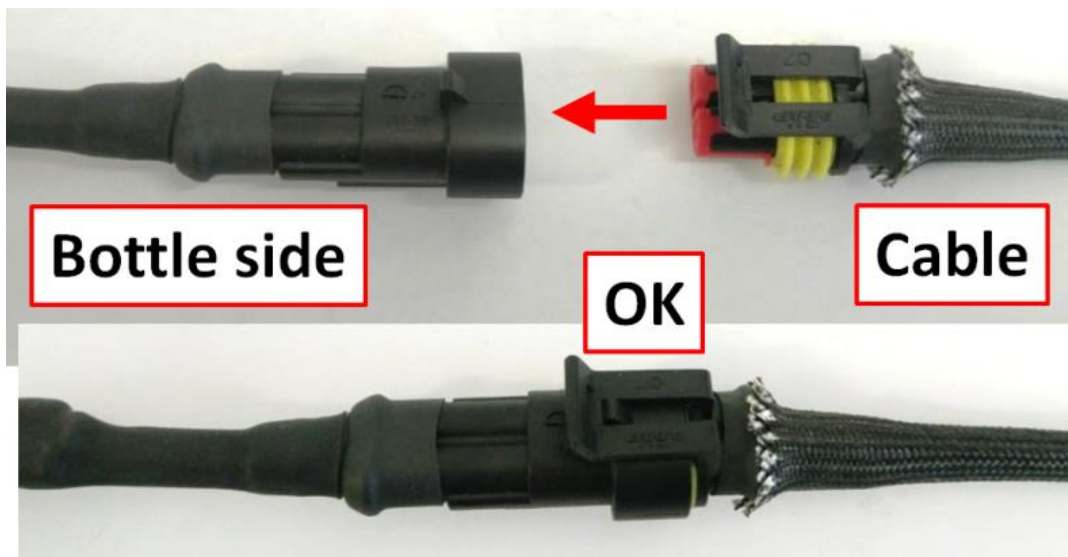

Fig. 7 Bottle connection



**WARNING**

**If the bottles are connected to the Control Units with one of the switches in ARMED position, the system might turn on even if electrical connection does not work properly.**

Once the installation is completed, check the system by setting the control unit switch to TEST mode and push the activation button. In this way, the control unit will confirm the proper installation as indicated before.

Note

The control unit checks the whole electrical system: if the bottle is not connected the result will be NOT OK.

If, after checking connections and installing a new 9V battery, the LED still does not turn on, contact your local retailer.

When the result is NOT OK, even in case of correct electrical connections, the bottle is connected to the system and the 9V battery is fully charged, please contact your OMP retailer.

**It is recommended to replace the electrical control unit 9V battery before every race.**