

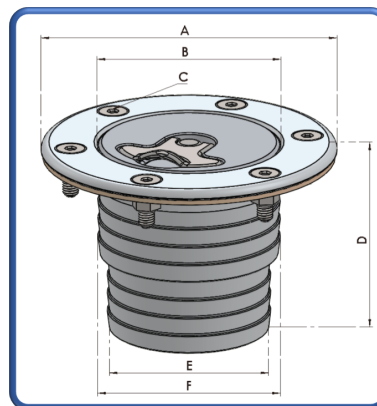

Aero 300

**A300 Fuel Filler Cap, Non-Locking, Non-vented, Silver,
Ø51.0/57.0 Integral Neck.
Part Number: OB-ZA-017 (A36NS2)**



Options:

Part Description

A300 Fuel Filler Cap, Locking, Non-Vented, Silver, Ø51.0/57.0 Integral Neck

A300 Fuel Filler Cap, Non-Locking, Non-Vented, Black, Ø51.0/57.0 Integral Neck

A300 Fuel Filler Cap, Locking, Non-vented, Black, Ø51.0/57.0 Integral Neck

Part Number

OB-ZA-031 (A36NL2)

OB-ZA-018 (A36NS2B)

OB-ZA-032 (A36NL2B)

Specifications:

Fixing Arrangement:

Applications:

Compatibilities:

Finish:

Weight:

Supplied With:

6 x M05 Countersunk Screws Equal Spaced

Fuel, Oil & Water Tanks

Extreme Fuels

Operation Temperature -40°C to +80°C

Anodised

270 grams

Centre Cap

6 Hole Flange Neck

M05 Screw Pack (CSK Screws, Washers, Nyloc Nuts)

NBR Cork Gasket

Materials:

Centre Cap:

O-Ring:

Saddle:

Lever & Centre Pin:

Washer & Nyloc Nut:

Gasket:

Aluminium Alloy 6082/T6 Forging

Viton A (FPM or FKM)

Acetal POM Kepital F20-03

Stainless Steel 303/304

Stainless Steel A2 Type

Neoprene NBR bonded Cork

Dimensions:

Outside Diameter A:

Centre Cap Diameter B:

Bolt Circle Diameter C:

Depth D:

Spigot:

Neck Diameter E/F:

Flange Thickness:

94.0mm

57.5mm

76.2mm

62.50mm

62.4 (Ø63.0 Cut-Out)

51.0/57.0mm

3.25mm

Optional('s):

Lanyard / Lead Free / Metal Saddle

Hard Anodising / Viton (FPM) Gasket

Fluid Containment – When It Matters

Tell: +4420 8594 7990 / Fax: +4420 8594 7989 / www.newton-equipment.com / info@newton-equipment.com

Registered in England. 6 Orwell Close/ Fairview Ind. Park/ Rainham/ Essex/ RM13 8UB