

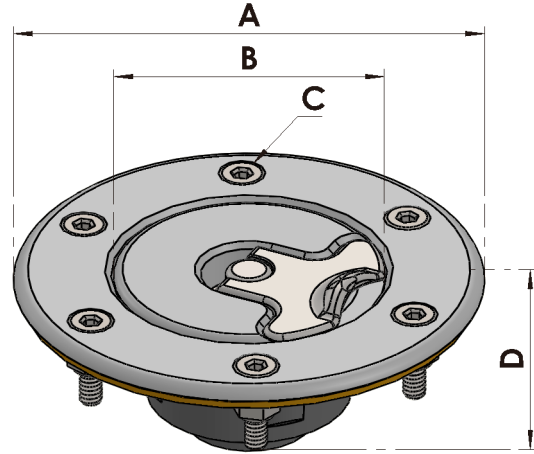

Aero 200

A200 Fuel Filler Cap, Non-Vented, Locking, Silver. Part Number: OA-ZA-001 (A26S)



Options:

Part Description

A200 Fuel Filler Cap, Non-Vented, Non-Lock, 6 Hole Flange, Black

Part Number

OA-ZA-003 (A26SBB)

Specifications:

Fixing Arrangement:

Applications:

Compatibilities:

Finish:

Weight:

Supplied With:

6 x M04 CSK Bolts

Fuel, Oil & Water Tanks

Compatible with Jet Fuel 100LL

Operation Temperature -40°C to +80°C

Anodised Clear (Silver)

82.0 grams

Cap

Flange

M04 Screw Pack (CSK Screws, Washers & Nyloc Nuts)

NBR Cork Gasket

Materials:

Centre Cap:

O-Ring:

Saddle:

Lever & Centre Pin:

Washer & Nyloc Nut:

Gasket:

Aluminium Alloy 6082/T6 Forging

Viton A (FPM or FKM)

Acetal POM Kepital F20-03

Stainless Steel 303/304

Stainless Steel A2 Type

Neoprene Bonded Cork (NBR)

Dimensions:

Outside Diameter A:

Centre Diameter B:

Bolts Circle Diameter C:

Depth D:

Spigot:

Neck Diameter:

Flange Thickness:

80.0mm

47.0mm

63.5mm

28.2mm (Adjustable)

50.5 (Ø51.50 Cut-Out)

N/A

2.5mm

Optional('s):

Lanyard

Metal Saddle

Hard Anodising

Viton (FPM) Gasket

Fluid Containment – When It Matters

Tell: +4420 8594 7990 / Fax: +4420 8594 7989 / www.newton-equipment.com / info@newton-equipment.com

Registered in England. 6 Orwell Close/ Fairview Ind. Park/ Rainham/ Essex/ RM13 8UB



Aero 200

A200 Fuel Filler Cap, Non-Vented, Locking, Silver, 6 Bolt Flange

Part Number: OA-ZA-030 (A26L)

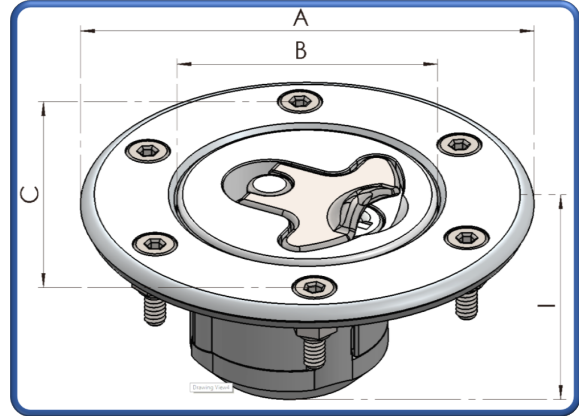
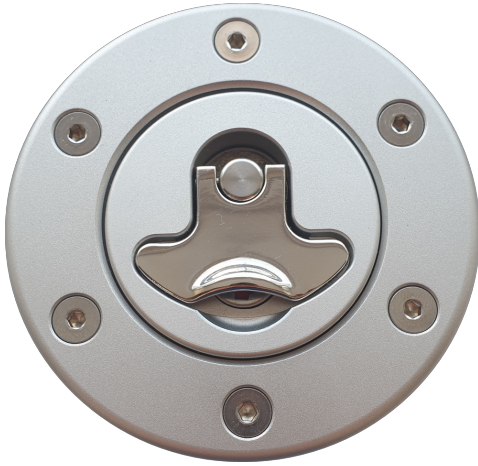

Options:

Part Description

A200 Fuel Filler Cap, Non-Vented, Locking, Black, 6 Hole Flange

Part Number

OA-ZA-036 (A26LBB)

Specifications:

Fixing Arrangement:

Applications:

Compatibilities:

Finish:

Weight:

Supplied With:

6 x M4 Countersunk Bolts

Fuel, Oil & Water Tanks

Compatible with Jet Fuel 100LL

Operation Temperature -40°C to +80°C

Anodised Clear (Silver)

84.0 grams

Locking Cap

Nitrile Bonded Cork Gasket

M4 Screw Pack (CSK Screws, Washers & Nyloc Nuts)

Flange

Materials:

Centre Cap:

Flange:

O-Ring:

Lever & Centre Pin:

Saddle:

Gasket:

Aluminium Alloy 6082/T6

Aluminium Alloy 6082/T6

Viton A (FPM or FKM)

Stainless Steel 303/304

Acetal POM

Neoprene Bonded Cork (NBR)

Dimensions:

Outside Diameter A:

Centre Diameter B:

Bolt Circle Diameter (PCD) C:

Overall Depth I:

Bore Diameter:

Spigot:

Neck Diameter:

Flange Thickness:

80.0mm

47.0mm

63.5mm

32.0mm Adjustable

35.50mm

50.5 (Ø51.50 Cut-Out)

N/A

2.5mm

Optional('s):

Lanyard

Hard Anodising

Viton (FPM) Gasket

Fluid Containment – When It Matters

Tell: +4420 8594 7990 / Fax: +4420 8594 7989 / www.newton-equipment.com / info@newton-equipment.com

Registered in England. 6 Orwell Close/ Fairview Ind. Park/ Rainham/ Essex/ RM13 8UB