

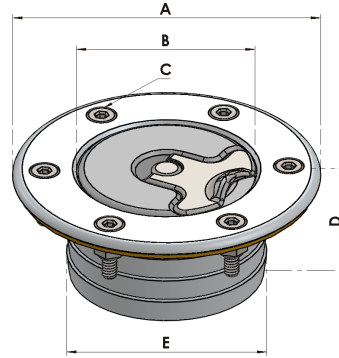

Aero 200

**A200 Fuel Filler Cap, Non-Locking, Non-vented, Silver,
Ø52.0 Integral Neck.**

Part Number: OA-ZA-005 (A26NS)



Options:

Part Description

A200 Fuel Filler Cap, Non-Locking, Non-Vented, Black, Ø52.0 Integral Neck

Part Number

OA-ZA-007 (A26NSBB)

Specifications:

Fixing Arrangement:

Applications:

Compatibilities:

Finish:

Weight:

Supplied With:

6 x M04 CSK Bolts

Fuel, Oil & Water Tanks

Compatible with Jet Fuel 100LL

Operation Temperature -40°C to +80°C

Anodised Clear (Silver)

135.0 grams

Cap

Flange Neck

M04 Screw Pack (CSK Screws, Washers & Nyloc Nuts)

NBR Cork Gasket

Materials:

Centre Cap:

Flange Neck:

O-Ring:

Saddle:

Lever & Centre Pin:

Washer & Nyloc Nut:

Gasket:

Aluminium Alloy 6063 Forging

Aluminium Alloy 6082/T6 Machined

Viton A (FPM or FKM)

Acetal POM Kepital F20-03

Stainless Steel 303/304

Stainless Steel A2 Type

Neoprene Bonded Cork (NBR)

Dimensions:

Outside Diameter A:

80.0mm

Centre Diameter B:

47.0mm

Bolts Circle Diameter C:

63.5mm

Depth D:

31.0mm

Spigot:

50.5 (Ø51.50 Cut-Out)

Neck Diameter E:

52.0mm

Flange Thickness:

2.5mm

Optional('s):

Lanyard

Metal Saddle

Hard Anodising

Viton (FPM) Gasket

Fluid Containment – When It Matters

Tell: +4420 8594 7990 / Fax: +4420 8594 7989 / www.newton-equipment.com / info@newton-equipment.com

Registered in England. 6 Orwell Close/ Fairview Ind. Park/ Rainham/ Essex/ RM13 8UB



Aero 200

**A200 Fuel Filler Cap, Locking, Non-Vented Silver,
Ø52.0 Integral Neck.**

Part Number: OA-ZA-031 (A26NL)

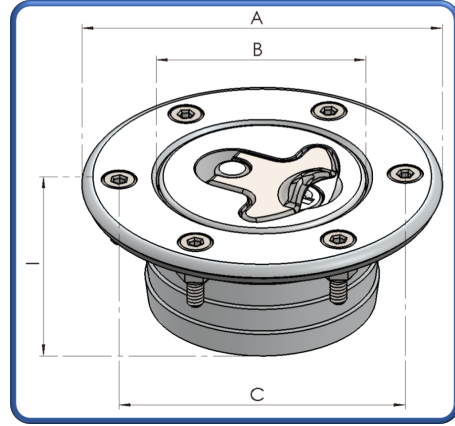

Options:

Part Description

A200 Fuel Filler Cap, Locking, Non-Vented, Black, Ø52.0 Integral Neck

Part Number

OA-ZA-038 (A26NLBB)

Specifications:

Fixing Arrangement:

Applications:

Compatibilities:

Finish:

Weight:

Supplied With:

6 x M4 Countersunk Bolts

Fuel, Oil & Water Tanks

Compatible with Jet Fuel 100LL

Operation Temperature -40°C to +80°C

Anodised Clear (Silver)

140 grams

Cap

Flange Neck

M04 Screw Pack (CSK Screws, Washers & Nyloc Nuts)

NBR Cork Gasket

Materials:

Centre Cap:

Flange Neck:

O-Ring:

Saddle:

Washer & Nyloc Nut:

Gasket:

Aluminium Alloy 6082/T6

Aluminium Alloy 6082/T6

Viton A (FPM or FKM)

Acetal POM

Stainless Steel A2 Type

Neoprene Bonded Cork (NBR)

Dimensions:

Outside Diameter A:

Centre Diameter B:

Bolt Circle Diameter (PCD) C:

Overall Depth I:

Spigot:

Neck Diameter:

Flange Thickness:

80.0mm

46.0mm

63.5mm

32.0mm

Ø50.0mm (Ø51.50 Cut-Out)

Ø52.0mm

2.5mm

Optional('s):

Lanyard

Hard Anodising

Viton (FPM) Gasket

Fluid Containment – When It Matters

Tell: +4420 8594 7990 / Fax: +4420 8594 7989 / www.newton-equipment.com / info@newton-equipment.com

Registered in England. 6 Orwell Close/ Fairview Ind. Park/ Rainham/ Essex/ RM13 8UB