

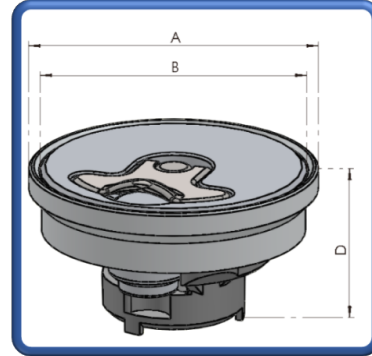

Aero 300

**A300 Fuel Filler Cap, Non-Locking, Non-vented, Silver,
Weld-On Ring.**

Part Number: OB-ZA-039 (A3NS)



Options:

Part Description

A300 Fuel Filler Cap, Locking, Non-Vented, Silver, Weld-On Ring

A300 Fuel Filler Cap, Non-Locking, Non-Vented, Black, Weld-On Ring

A300 Fuel Filler Cap, Locking, Non-vented, Black, Weld-On Ring

Part Number

OB-ZA-043 (A3NL)

OB-ZA-042 (A3NSPB)

OB-ZA-046 (A3NLPB)

Specifications:

Fixing Arrangement:

Applications:

Compatibilities:

Finish:

Weight:

Supplied With:

Weld-On or Adhesive

Fuel, Oil & Water Tanks

Extreme Fuels

Operation Temperature -40°C to +80°C

Anodised

110.0 grams

Centre Cap

Weld-On Ring

Materials:

Centre Cap:

Weld-On Ring:

O-Ring:

Saddle:

Lever & Centre Pin:

Washer & Nyloc Nut:

Aluminium Alloy 6063/T6 Forging

Aluminium Alloy 6082/T6

Viton A (FPM or FKM)

Acetal POM Kepital F20-03

Stainless Steel 303/304

Stainless Steel A2 Type

Dimensions:

Outside Diameter A:

Centre Cap Diameter B:

Bolt Circle Diameter C:

Depth D:

Spigot:

Neck Diameter E/F:

Flange Thickness:

62.50mm

57.5mm

N/A

33.0mm

57.0 (Ø58.0 Cut-Out)

N/A

N/A

Optional('s):

Lanyard

Metal Saddle

Hard Anodising

Fluid Containment – When It Matters

Tell: +4420 8594 7990 / Fax: +4420 8594 7989 / www.newton-equipment.com / info@newton-equipment.com

Registered in England. 6 Orwell Close/ Fairview Ind. Park/ Rainham/ Essex/ RM13 8UB