

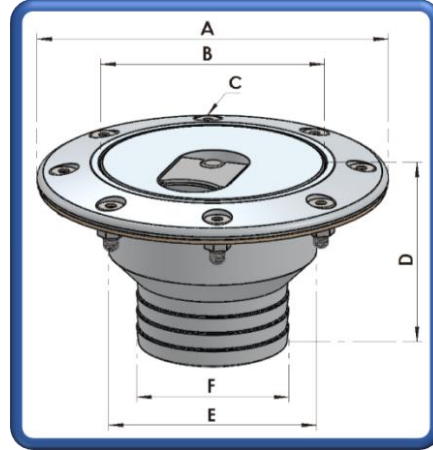

Aero 400

**A400 Fuel Filler Cap, Non-Vented, Non-Locking, Silver,
Ø57.0 Integral Neck.**

Part Number: OC-ZA-011 (A48NS57)



Options:

Part Description

A400 Fuel Filler Cap, Non-Vented, Locking, Silver, Ø51.0 Integral Neck:

A400 Fuel Filler Cap, Non-Vented, Non-Locking, Black, Ø51.0 Integral Neck:

A400 Fuel Filler Cap, Non-Vented, Locking, Black, Ø51.0 Integral Neck:

Part Number

OC-ZA-015 (A48NL57)

OC-ZA-036 (A48NS57B)

OC-ZA-037 (A48NL57B)

Specifications:

Fixing Arrangement:

Applications:

Compatibilities:

Finish:

Weight:

Supplied With:

8 x M05 CSK Bolts

Fuel, Oil & Water Tanks

Compatible with Jet Fuel 100LL

Operation Temperature -40°C to +80°C

Anodised Clear

395.0 grams

Cap

Flange neck

M05 Screw Pack (CSK Screws, Washers & Nyloc Nuts)

NBR Cork Gasket

Materials:

Centre Cap:

O-Ring:

Saddle:

Lever & Centre Pin:

Washer & Nyloc Nut:

Gasket:

Aluminium Alloy 6082/T6

Viton A (FPM or FKM)

Acetal POM Kepital F20-03

Stainless Steel 303/304

Stainless Steel A2 Type

Neoprene Bonded Cork (NBR)

Dimensions:

Outside Diameter A:

Centre Diameter B:

Bolts Circle Diameter C:

Depth D:

Spigot E:

Neck Diameter F:

Flange Thickness:

120.0mm

76.5mm

101.6mm

35.5mm (Adjustable)

80.0 (Ø81.0 Cut-Out)

57.0mm

6.0mm

Optional('s):

Lanyard (Must Have Lead-Free Flap "Optional)

Hard Anodising

Viton (FPM) Gasket

Lead-Free Flap

Fluid Containment – When It Matters

Tell: +4420 8594 7990 / Fax: +4420 8594 7989 / www.newton-equipment.com / info@newton-equipment.com

Registered in England. 6 Orwell Close/ Fairview Ind. Park/ Rainham/ Essex/ RM13 8UB