

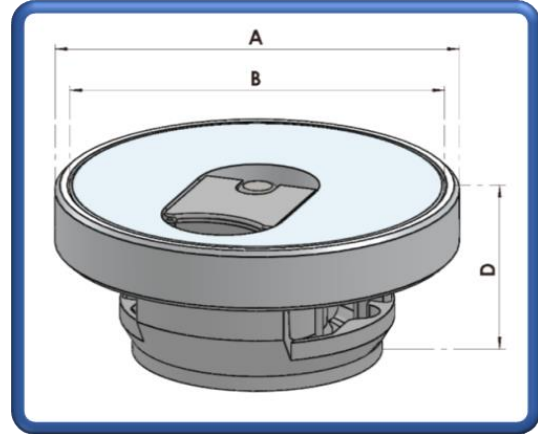

Aero 400

A400 Fuel Filler Cap, Non-Vented, Non-Locking, Weld-On Ring, Silver.

Part Number: OC-ZA-017 (A4NS)



Options:

Part Description

A400 Fuel Filler Cap, Non-Vented, Locking, Silver, Weld-On Ring:

A400 Fuel Filler Cap, Non-Vented, Non-Locking, Black, Weld-On Ring:

A400 Fuel Filler Cap, Non-Vented, Locking, Black, Weld-On Ring:

Part Number

OC-ZA-018 (A4NL)

OC-ZA-038 (A4NSB)

OC-ZA-039 (A4NLB)

Specifications:

Fixing Arrangement:

Applications:

Compatibilities:

Finish:

Weight:

Supplied With:

Weld-On or Adhesive

Fuel, Oil & Water Tanks

Compatible with Jet Fuel 100LL

Operation Temperature -40°C to +80°C

Anodised Clear

145.0 grams

Cap

Weld-On Ring

Materials:

Centre Cap:

O-Ring:

Saddle:

Lever & Centre Pin:

Washer & Nyloc Nut:

Gasket:

Aluminium Alloy 6082/T6

Viton A (FPM or FKM)

Acetal POM Kepital F20-03

Stainless Steel 303/304

Stainless Steel A2 Type

Neoprene Bonded Cork (NBR)

Dimensions:

Outside Diameter A:

Centre Diameter B:

Bolts Circle Diameter C:

Depth D:

Spigot E:

Neck Diameter:

Flange Thickness:

82.5mm

76.5mm

N/A

35.5mm (Adjustable)

80.0 (Ø81.0 Cut-Out)

N/A

N/A

Optional('s):

Lanyard

Hard Anodising

Fluid Containment – When It Matters

Tell: +4420 8594 7990 / Fax: +4420 8594 7989 / www.newton-equipment.com / info@newton-equipment.com

Registered in England. 6 Orwell Close/ Fairview Ind. Park/ Rainham/ Essex/ RM13 8UB