

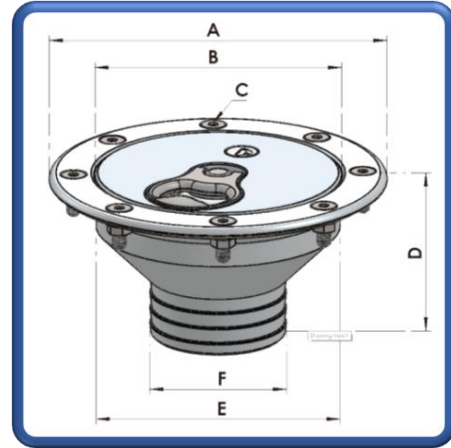

Aero 600

**A600 Fuel Filler Cap, Non-Vented, Locking, Silver,
Ø57.0 Integral Neck.**

Part Number: OE-ZA-008 (A68NL57)



Options:

Part Description

A500 Fuel Filler Cap, Non-Vented, Non-Locking, Silver, Ø57.0 Integral Neck:

Part Number

OE-ZA-006 (A68NS57)

Specifications:

Fixing Arrangement:

Applications:

Compatibilities:

Finish:

Weight:

Supplied With:

8 x M05 CSK Bolts

Fuel, Oil & Water Tanks

Compatible with Jet Fuel 100LL

Operation Temperature -40°C to +80°C

Anodised

245.0 grams

Cap

Flange Neck

Screw Pack (CSK Bolts, Washers & Nyloc Nuts)

Gasket

Materials:

Centre Cap:

O-Ring:

Saddle:

Lever & Centre Pin:

Washer & Nyloc Nut:

Gasket:

Aluminium Alloy 6082/T6

Viton A (FPM or FKM)

Acetal POM Kepital F20-03

Stainless Steel 303/304

Stainless Steel A2 Type

Neoprene Bonded Cork (NBR)

Dimensions:

Outside Diameter A:

Centre Diameter B:

Bolts Circle Diameter C:

Depth D:

Spigot E:

Neck Diameter:

Flange Thickness:

126.0mm

92.0mm

108.0mm

60.0mm

98.6 (Ø100 Cut-Out)

57.0mm

3.25mm

Optional('s):

Lanyard

Hard Anodising

Viton (FPM) Gasket

Fluid Containment – When It Matters

Tell: +4420 8594 7990 / Fax: +4420 8594 7989 / www.newton-equipment.com / info@newton-equipment.com

Registered in England. 6 Orwell Close/ Fairview Ind. Park/ Rainham/ Essex/ RM13 8UB